

REV.1

**QUAD**  
INDUSTRIAL

# CONCOURSE C SERIES

## INSTRUCTION BOOKLET



MODELS C4, C4-T, C4-16, C6, C8, & CSUB

**FOR THE CLOSEST APPROACH TO THE ORIGINAL SOUND**

## TABLE OF CONTENTS

### Introduction:

Safety Instructions.....	02
Warnings & Disclaimers.....	02
Rigging & Suspension.....	02
Warranty & Service.....	02

### Product Descriptions:

C4, C4-16, C4-T, C6, C8, & CSUB.....	03
--------------------------------------	----

### Product Features:

Product Diagram.....	04
Components.....	05
Dimension Drawings.....	06

### Installation - Suspended Tile Ceilings:

Installation Instructions.....	07
--------------------------------	----

### Installation - Hard Ceilings:

Installation Instructions.....	09
--------------------------------	----

### Connections:

Input Connectors.....	11
Number of Speakers Calculation.....	11
Recommened Wiring Scheme.....	11

### CE Compliance:

Statement.....	12
----------------	----

### Product Specifications

Specifications.....	13
---------------------	----

### Contact Information:

QUAD Industrial Contact Information.....	BACK COVER
--	------------

## SAFETY INSTRUCTIONS

### Safety First!

1. Please read this manual fully before installing and operating this product.
2. Retain a copy of this manual for future reference.
3. Comply with all warning labels and instructions.
4. Do not attempt the installation of this equipment unless you are qualified to do so.
5. Protect your hearing from high sound pressure levels.

### Rigging and Suspension

The rigging, suspension or mounting of these products can expose the installer and members of the public to serious health risks and even death.

**UNDER NO CIRCUMSTANCES ATTEMPT TO RIG, SUSPEND OR OTHERWISE MOUNT THIS EQUIPMENT UNLESS YOU ARE FULLY QUALIFIED AND CERTIFIED TO DO SO BY RELEVANT LOCAL, STATE AND NATIONAL AUTHORITIES. ALL RELEVANT SAFETY REGULATIONS MUST BE FOLLOWED. IF YOU ARE NOT PROPERLY QUALIFIED OR DO NOT KNOW OF PERTINENT REGULATIONS, CONSULT QUALIFIED PERSONNEL FOR ADVICE AND ASSISTANCE.**

### Limited Liability

QUAD Industrial assumes no liability whatsoever for any damage or loss, either direct or consequential arising from the installation and use of these products. Liability is limited to replacement of product or refund, at the QUAD Industrial's discretion. Your rights to compensation may vary by territory; consult with your local QUAD Industrial office or distributor.

### Warranty & Service

These products are designed to be used as specified, and are warranted to be free from defects in materials or workmanship. Warranty terms and conditions vary by territory. Please contact your local QUAD Industrial sales office or distributor for complete details. Under no circumstances should you attempt to repair these products. Doing so may limit or void warranty coverage.

## PRODUCT DESCRIPTION

The Concourse C series are two-way, high performance ceiling mounted speaker systems designed for distributed music, paging and speech applications. Packaged in pairs (except the C-SUB and C-SUBT) and including all needed mounting accessories, the C series models are complete vented speaker assemblies with a metal back box, ABS front baffle and attractive metal grille. Each model is available in both low-impedance 16Ω and constant-voltage 70/100V versions (with T suffix).

### CONCOURSE C4/C4-16/C4T

The Concourse C4 is a two-way ceiling mounted speaker system consisting of a 4" cone low frequency driver and a 1" soft dome tweeter. Speakers are packed in pairs and come complete with a tile backing C-ring, mounting support rails plastic paint covers and cardboard cutout templates. There are three versions available:

- **Concourse C4** – Selectable 4Ω/16Ω/70V/100V operation, 30W transformer included
- **Concourse C4-16** – 16Ω version, 25 Watts
- **Concourse C4T** – 70/100 Volt operation only, 30W transformer included

### Concourse C6

The Concourse C6 is a two-way ceiling mounted speaker system consisting of a 6" cone low frequency driver and a 1" soft dome tweeter. Speakers are packed in pairs and come complete with a tile backing C-ring, mounting support rails plastic paint covers and cardboard cutout templates.

- **Concourse C6** – Selectable 4Ω/16Ω/70V/100V operation, 50W transformer included

### Concourse C8

The Concourse C8 is a two-way ceiling mounted speaker system consisting of an 8" dual voice coil cone low frequency driver and a 1" soft dome tweeter. Speakers are packed in pairs and come complete with a tile backing C-ring, mounting support rails, plastic paint covers and cardboard cutout templates.

- **Concourse C8** – Selectable 4Ω/16Ω/70V/100V operation, 60W transformer included

### Concourse CSUB

The Concourse CSUB is a ceiling mounted subwoofer system consisting of a 10" sub bass driver and integral low-pass crossover. The CSUB is fitted with dual low-impedance voice coils allowing connection to stereo power amplifiers at either 4Ω or 16Ω, or to 70/100V amplifiers through a built-in 100W transformer.

- **Concourse CSUB** – Selectable 4Ω/16Ω/70V/100V operation, dual 50W low impedance coils, 100W transformer included

## PRODUCT FEATURES

All models include the following components:

- **Speaker assembly (2)**
- **Cover grille with restraint (2)**
- **Split C ring backing plate (2)**
- **Support Rails (4)**
- **Plastic paint cover (2)**
- **Cardboard cutout template (2)**

Please ensure that you are familiar with all of the parts and how they are assembled before commencing the installation.

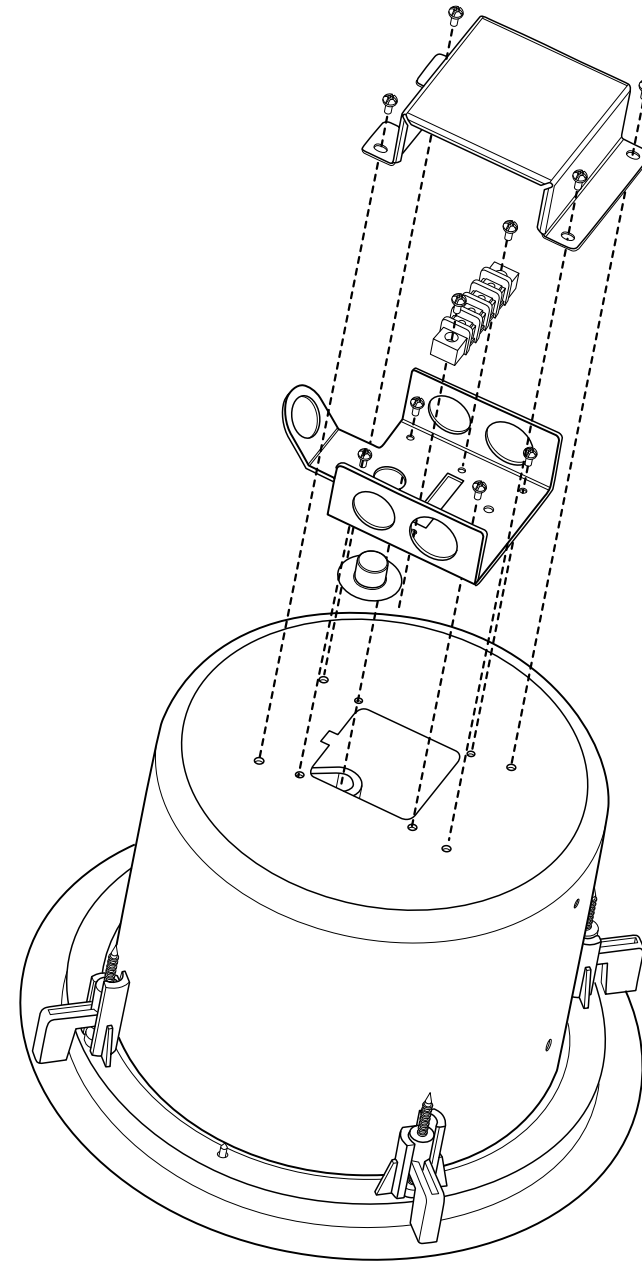
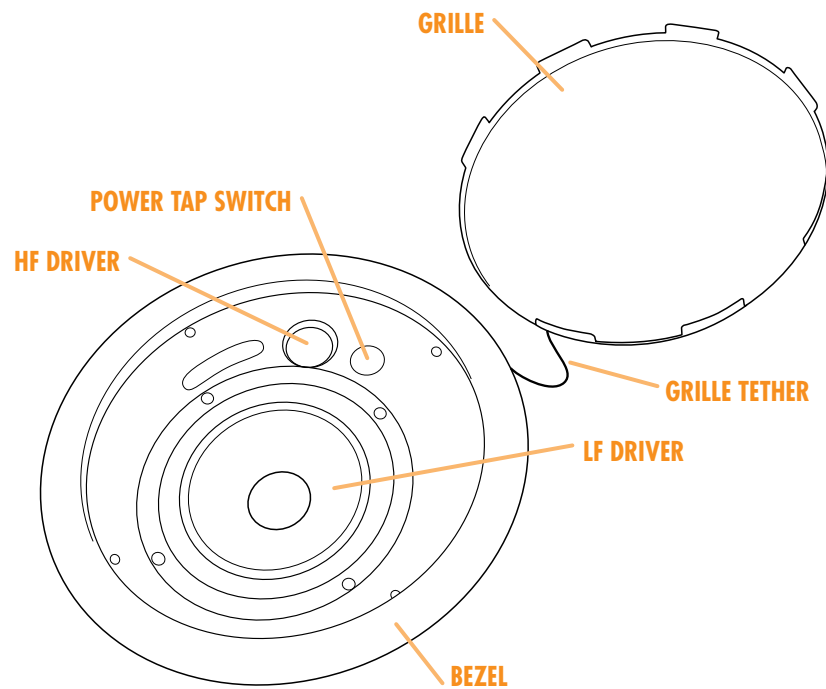

## PRODUCT DESCRIPTION

Concourse C models are complete assemblies ready for installation into both suspended tile ceilings and hard ceilings. A rear mounted terminal box allows termination of the speaker wiring to the speaker as well as impedance selection (except C4T and C4-16). Power taps are selected on 70/100V versions through a front mounted rotary switch.

Speakers are mounted by means of four mounting clamps located around the rear face of the bezel. A metal split C ring is provided to distribute the clamping pressure evenly along the ceiling surface. A pair of metal mounting support rails are provided for added support when the speakers are installed in a suspended tile ceiling.

A seismic restraint point is provided on the rear of the speaker to facilitate attachment of a restraint tether to the building's structure. The removable front grille is also fitted with a restraint tether that attaches to the inside of the bezel by means of a supplied insert.

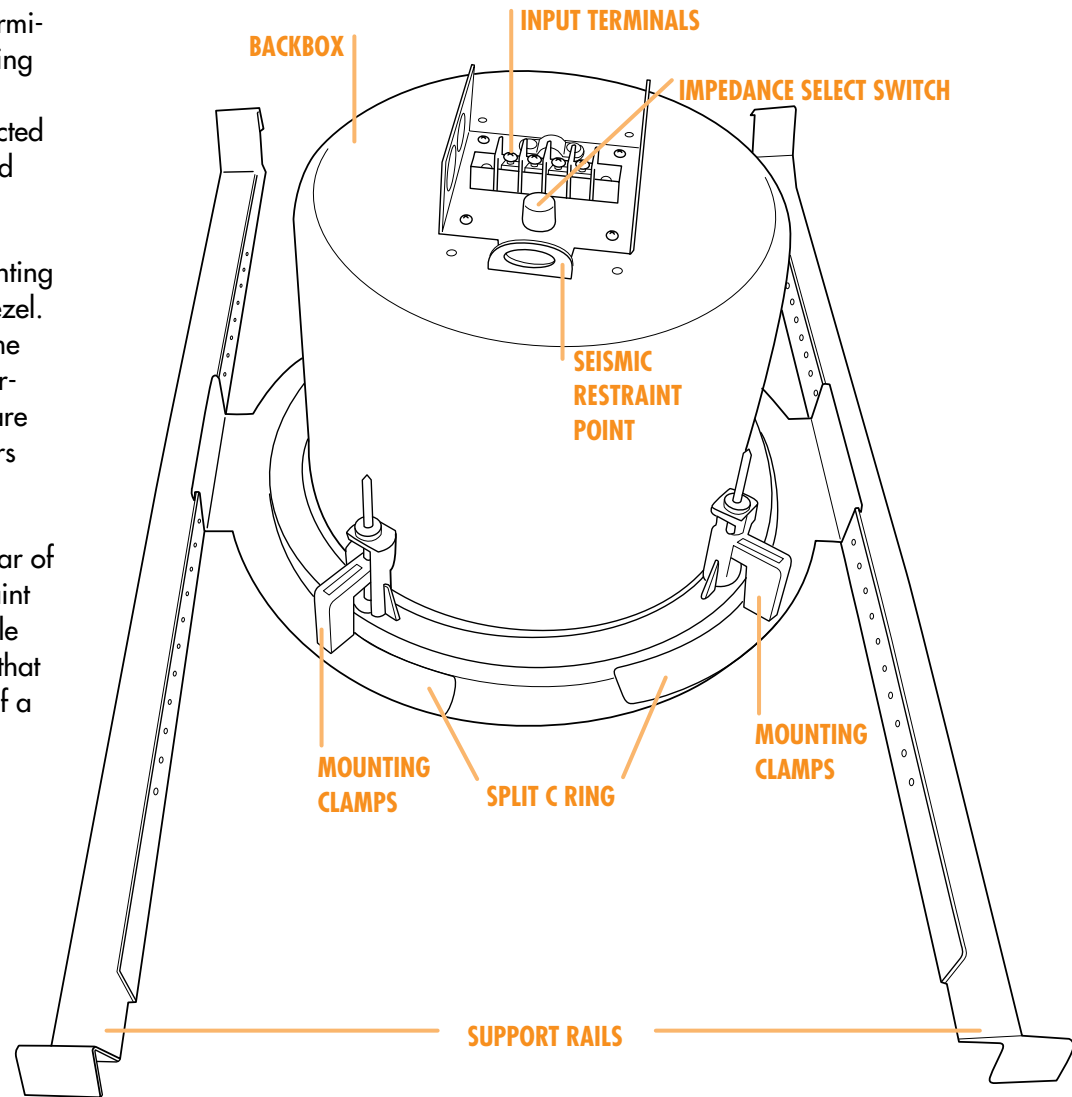

### Concourse C4, C4-T, C4-16

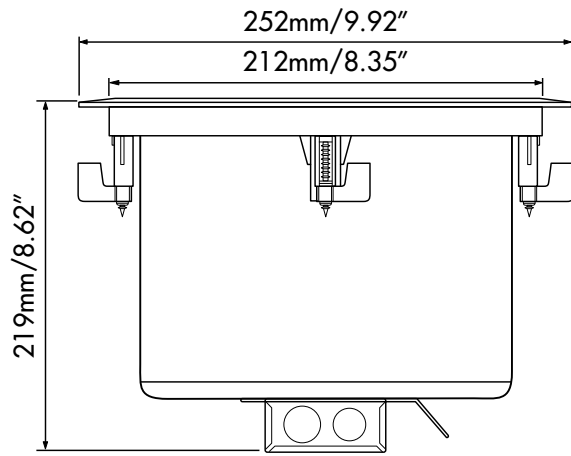

### Concourse C6

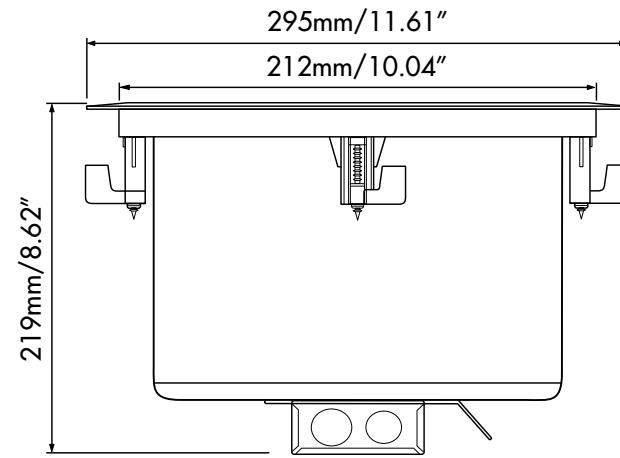

### Concourse C8

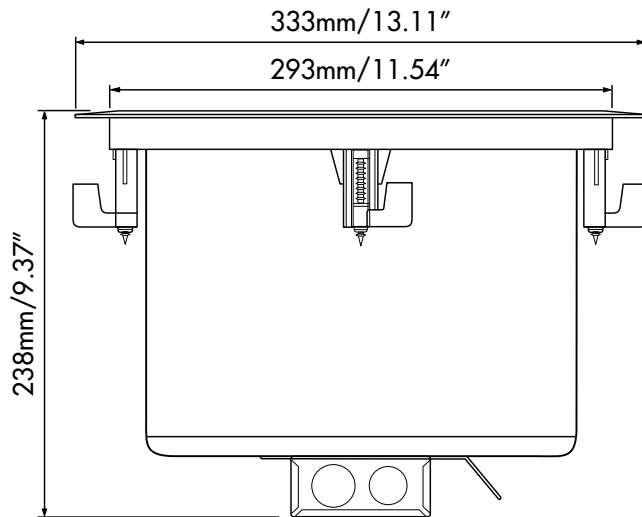

### Concourse CSUB

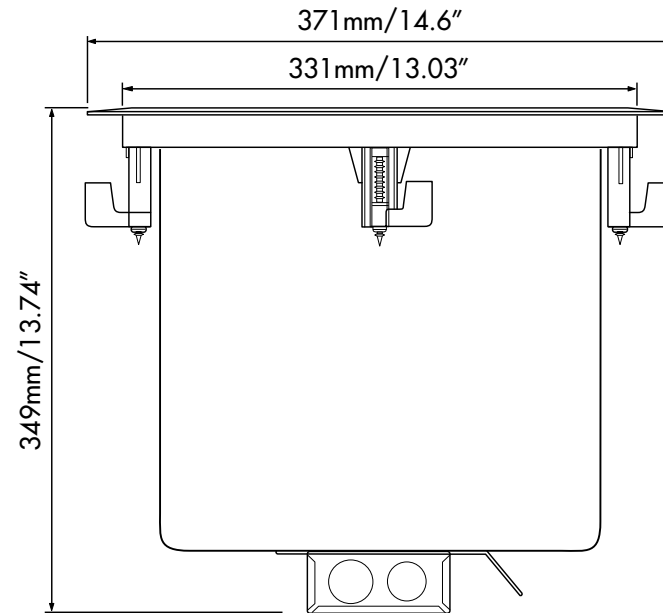

# INSTALLATION

## Suspended Tile Ceilings

### Step 1

Carefully unpack the contents of the box and ensure that all parts are accounted for before beginning installation.

### Step 2

Remove the tile from the ceiling and place it on a suitable work surface to cut the hole and assemble the speaker. Locate the cardboard mounting template and use it to mark the hole size needed for the installation. Center the template on the ceiling tile and cut the hole using a suitable saw, or knife.

### Step 3

Once the hole is cut, rest the speaker face-down on the work surface and place the cut ceiling tile over top of the assembly, ensuring the tile is resting on the speaker bezel.

### Step 4

Place the mounting rails on the ceiling tile on either side of the speaker assembly ensuring that they are oriented correctly to provide support by resting on the tile mounting grid when installed in the ceiling.

### Step 5

Place the C ring over top of the speaker assembly and align it with the mounting rails. Using the supplied screws, fasten the C ring to the mounting rails.

### Step 6

Lift the assembly to gain access to the front of the speaker, then using a screwdriver tighten each of the four mounting screws in sequence. Turning the screws in a clockwise direction will cause the mounting clamps to rotate into position then extend down to clamp the assembly to the ceiling tile.

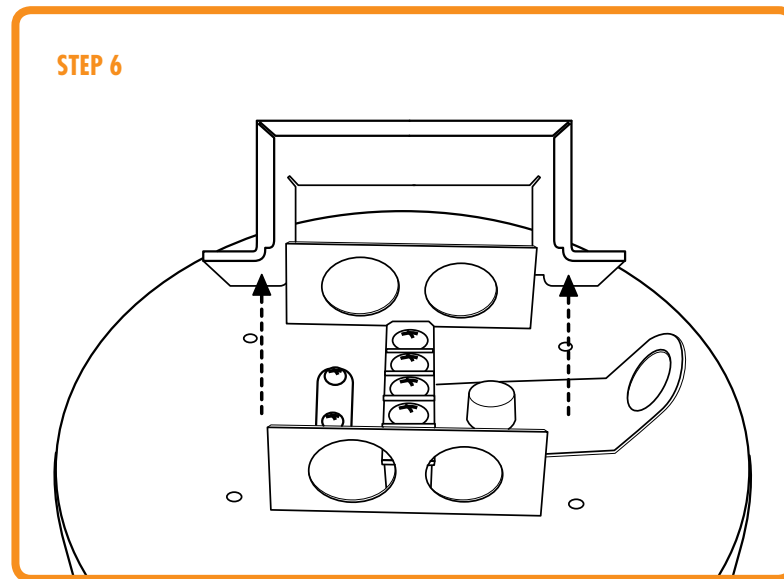
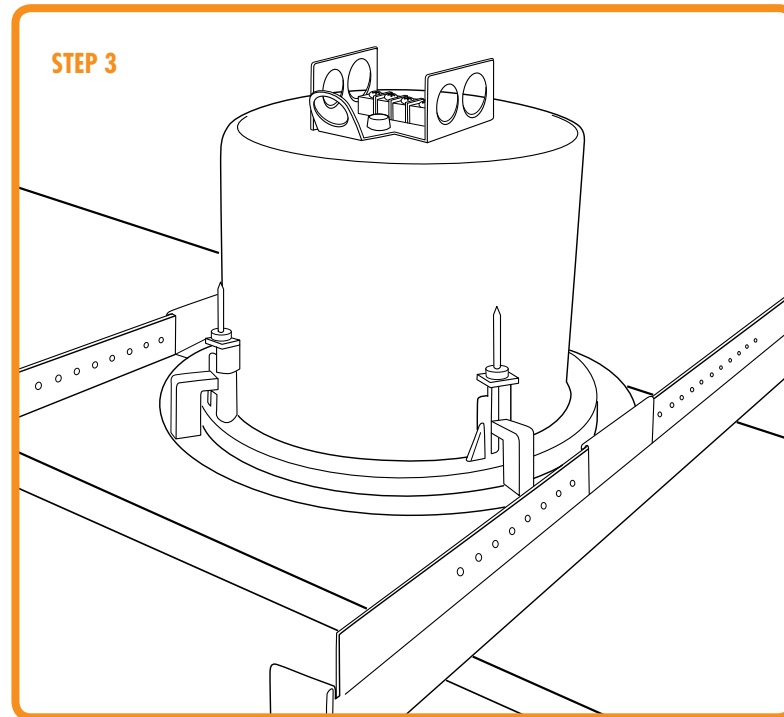

### Step 7

Remove the screws holding the terminal cover plate and then remove any knock outs needed to connect the speaker wiring.

### Step 8

Select the appropriate impedance using the push-button switch inside the terminal box if the speaker is part of a low impedance system (except C4-T and C4-16).

### Step 9

Lift the entire assembly to the ceiling and terminate the wiring to the terminal strip. Replace the cover plate and screws.

### Step 10

Place the assembled speaker and ceiling tile into the ceiling grid, ensuring that the mounting rails are resting correctly on the grid.

### Step 11

Set the correct wattage tap (except C4-16) using the front mounted rotary power switch. NOTE: The switch is labeled for both 70V and 100V power taps; ensure you select the correct tap for the connected amplifier.

### Step 12

If the speaker bezel is to be painted, place the supplied clear plastic paint cover over the front. Otherwise, attach the grille restraint tether by inserting the plastic plug into the hole on the inside of the bezel and then seat the grille to the bezel by pushing firmly around the perimeter of the grille.

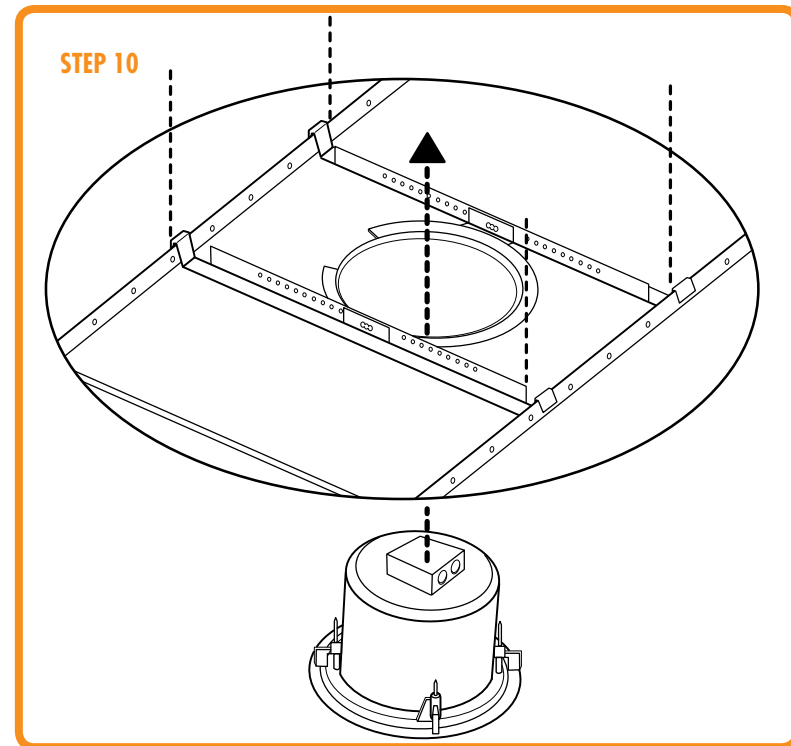
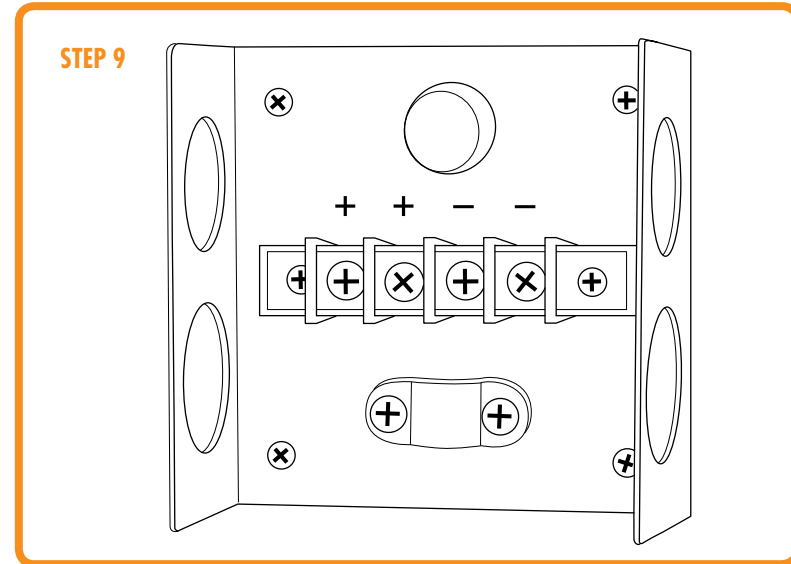



## INSTALLATION

### Hard Ceilings

**NOTE:** Installation into a hard ceiling requires that you first ensure that the location is suitable and that there are no obstacles behind the ceiling material. Use **EXTREME CAUTION** when cutting into hard ceilings to avoid severing electrical wiring, heating ducts or water pipes.

#### Step 1

Carefully unpack the contents of the box and ensure that all parts are accounted for before beginning installation.

#### Step 2

Locate the cardboard mounting template and use it to mark the hole size needed for the installation. Cut the mounting hole using a suitable saw.

#### Step 3

Once the hole is cut, insert the split C ring by twisting slightly and rotating it into the hole. Center the C ring around the opening.

#### Step 4

Remove the screws holding the terminal cover plate and then remove any knock outs needed to connect the speaker wiring.

#### Step 5

Select the appropriate impedance using the push-button switch inside the terminal box if the speaker is part of a low impedance system (except C4T and C4-16).

#### Step 6

Lift the speaker to the ceiling and terminate the wiring to the terminal strip. Replace the cover plate and screws.

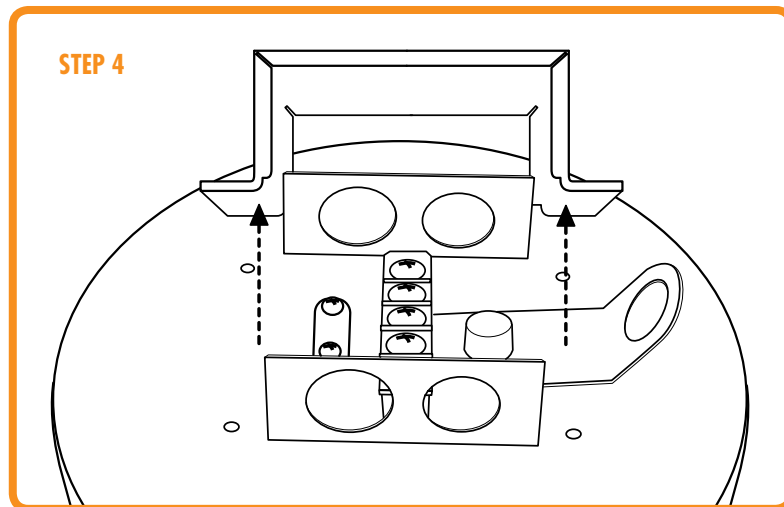
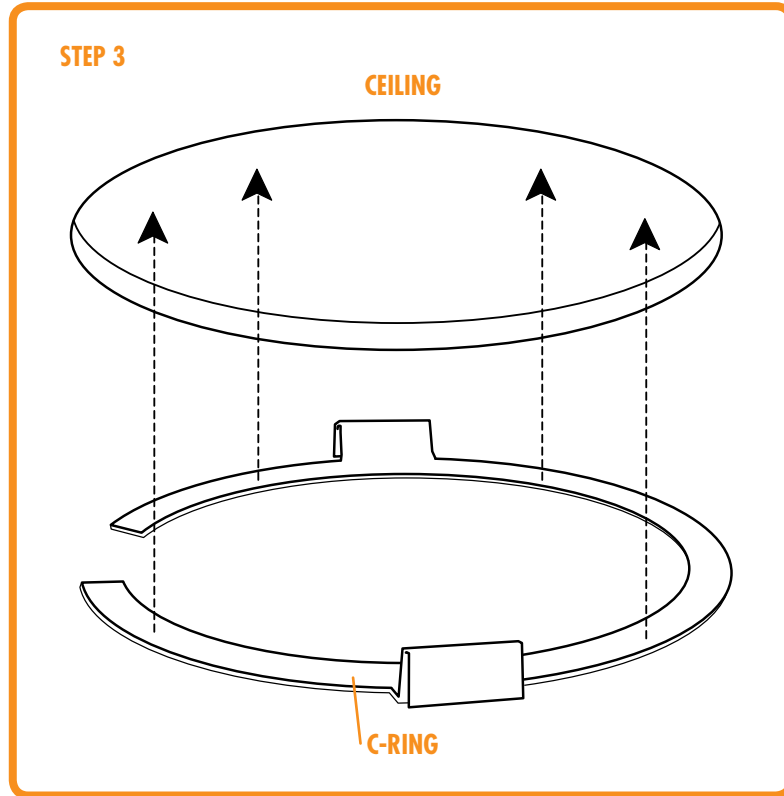

### Step 7

Lift the speaker into the opening, then using a screwdriver tighten each of the four mounting screws in sequence. Turning the screws in a clockwise direction will cause the mounting clamps to rotate into position then extend down to clamp the assembly to the ceiling.

### Step 8

Set the correct wattage tap (except C4-16) using the front mounted rotary power switch. NOTE: The switch is labeled for both 70V and 100V power taps; ensure you select the correct tap for the connected amplifier.

### Step 9

If the speaker bezel is to be painted, place the supplied clear plastic paint cover over the front. Otherwise, attach the grille restraint tether by inserting the plastic plug into the hole on the inside of the bezel and then seat the grille to the bezel by pushing firmly around the perimeter of the grille.

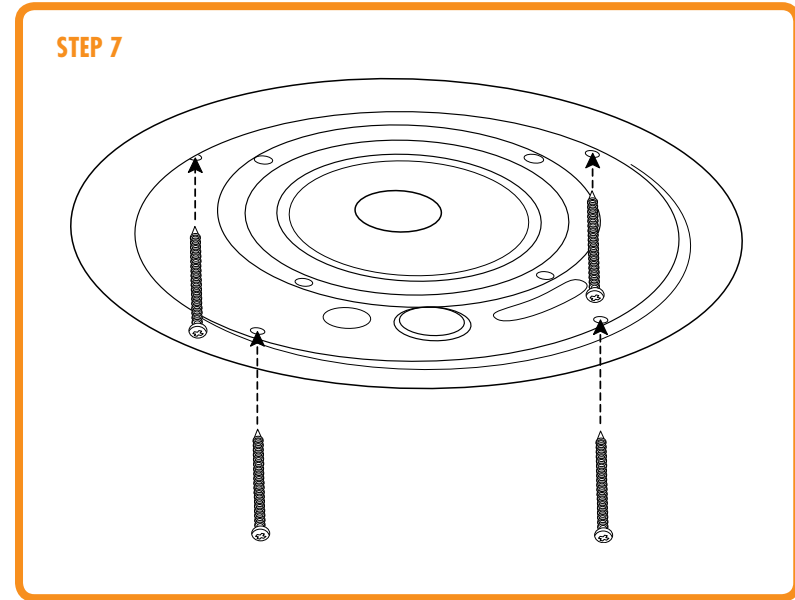

## WIRING & CONNECTIONS

Ensure that all wiring is installed in compliance with local laws, codes and convention. Obtain all necessary permits and approvals and use only cable that is approved for the application and is sized to safely accommodate the load.

### Models C4 / C4-T / C6 / C8 and CSUB

These models include two internal crossover networks allowing either 4Ω or 16Ω low impedance operation. In addition they include 70/100V transformers for use in distributed systems.

For 70/100V operation select the appropriate wattage tap using the rotary selector switch. Note that one side of the switch is labeled for 70V operation and the other side for 100V systems. Ensure that the power is set for the correct amplifier connected.

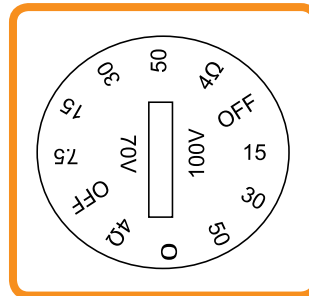

**NOTE: DO NOT USE THE "0" SETTING WHEN CONNECTED TO A 100V SOURCE!**

Select the power tap by dividing the amplifier's available power by the number of speakers to be connected and then selecting the next lower wattage tap. For example:

**300W amplifier ÷ 20 speakers = 15 Watts; use the 15W terminal**

Individual speakers may be tapped higher or lower in order to better balance the system sound pressure level in different areas. Ensure that the combined power draw does not exceed the rated power of the amplifier or else damage to the amplifier and speakers may occur. All 70/100V speakers should be wired in parallel as shown to the right.

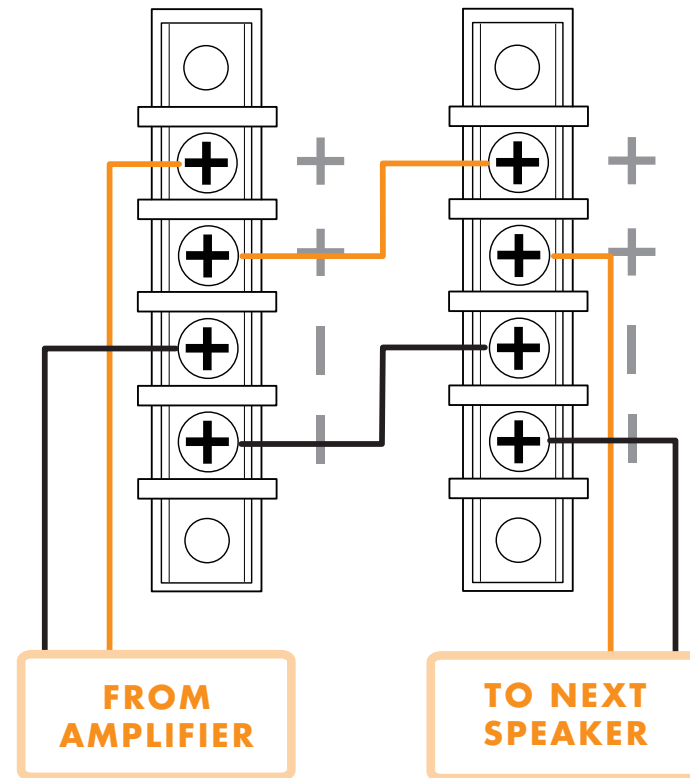

For low impedance operation first set the rotary switch to indicate the 4Ω setting. Then remove the terminal cover plate and note the position of the push-button switch. When the switch is in the “UP” position it indicates that the system is in 4Ω mode. When the switch is in the “DOWN” position it indicates that the system is in 16Ω mode.

**CAUTION:** Calculate the total load impedance before connecting the power amplifier. Do not exceed the number of speakers that the amplifier can drive safely:

<b>Amplifier Minimum Impedance</b>	<b>2Ω</b>	<b>4Ω</b>	<b>8Ω</b>
<b>Number of 16Ω Speakers in Parallel</b>	8	4	2
<b>Number of 8Ω Speakers in Parallel</b>	4	2	1
<b>Number of 4Ω Speakers in Parallel</b>	2	1	NO

## MODEL C4-16

The C4-16 is a fixed impedance speaker that offers 16 ohm impedance. The C4-16 is designed for direct connection to low impedance amplifiers in applications that require relatively few speakers located on close proximity to the amplifier.

Connect multiple speakers in parallel ensuring that the effective speaker load is compatible with the minimum load impedance of the connected power amplifier.

## COMPLIANCE

This product is in compliance with CE directives and bears the CE mark. For detailed information on specific directives please contact your local QUAD Industrial sales office or distributor.

## SPECIFICATIONS (C4/C4-T/C6/C8/CSUB/C4-16)

<b>Power Handling:</b>	<b>C4</b>	<b>C4-T</b>	<b>C6</b>	<b>C8</b>	<b>CSUB</b>	<b>C4-16</b>
Continuous	25W	25W	50W	75W	100W	25W
Program	50W	50W	100W	150W	200W	50W
Peak	100W	100W	200W	300W	400W	100W
<b>Frequency Response: (-10dB)</b>	55Hz–20kHz	55Hz–20kHz	50Hz–20kHz	45Hz–20kHz	28Hz–500Hz	55Hz–20kHz
<b>Frequency Response: (+/-3dB)</b>	70Hz–20kHz	70Hz–20kHz	70Hz–20kHz	55Hz–20kHz	43Hz–120Hz	70Hz–20kHz
<b>Sensitivity (@2.83V):</b>	84dB	84dB	86dB	88dB	80dB	84dB
<b>Max SPL:</b>	104dB	104dB	109dB	113dB	106dB	104dB
<b>Coverage (H x V):</b>	110° x 90°	110° x 90°	110° x 90°	110° x 90°	∅	110° x 90°
<b>Directivity (DI) (H x V):</b>	5.34	5.34	3.10	5.82	∅	5.34
<b>Impedance:</b>	4 & 16Ω	∅	4 & 16Ω	4 & 16Ω	4 & 16Ω	16Ω
<b>Transducers:</b>						
LF Driver Size	4" Cone	4" Cone	6" Cone	8" Cone	10" Long Throw	4" Cone
MID Driver Size	∅	∅	∅	∅	∅	∅
HF Driver Size	1" Soft Dome Tweeter	1" Soft Dome Tweeter	1" Soft Dome Tweeter	1" Soft Dome Tweeter	∅	1" Soft Dome Tweeter
<b>Crossover Frequency:</b>	2.2kHz	2.2kHz	2.5kHz	2.3kHz	150Hz LPF	2.2kHz
<b>Enclosure Material:</b>	Plastic (ABS) metal can	Plastic (ABS) metal can	Plastic (ABS) metal can	Plastic (ABS) metal can	Plastic (ABS) metal can	Plastic (ABS) metal can
<b>Connector Type:</b>	Screw Terminal	Screw Terminal	Screw Terminal	Screw Terminal	Screw Terminal	Screw Terminal
<b>Dimensions: (W x D)</b>	9.92" x 8.62" 252 x 219mm	9.92" x 8.62" 252 x 219mm	11.61" x 8.62" 295 x 219mm	13.11" x 9.37" 333 x 238mm	14.6" x 13.74" 371 x 349mm	9.92" x 8.62" 252 x 219mm
<b>Net Weight:</b>	2.75kg 6.05lbs.	2.6kg 5.73lbs.	4.1kg 9.02lbs.	5.3kg. 11.66lbs.	9.4kg 20.68lbs.	2.2kg 4.84lbs.

\* Features, details & specifications are subject to change without notice

**USA CONTACT:**

ph +1.877.440.0888

ph +1.425.861.3909

fx +1.425.861.3906

**UK CONTACT:**

ph +44 (0) 845 4580011

ph +44 (0) 1480 447700

fx +44 (0) 1480 431767

**OUTSIDE USA & UK:**

ph +86 (0) 755 8209 6639

fx +86 (0) 755 8209 0203

**WEB:**

[www.quadindustrial.com](http://www.quadindustrial.com)

**FOR THE CLOSEST APPROACH TO THE ORIGINAL SOUND**