

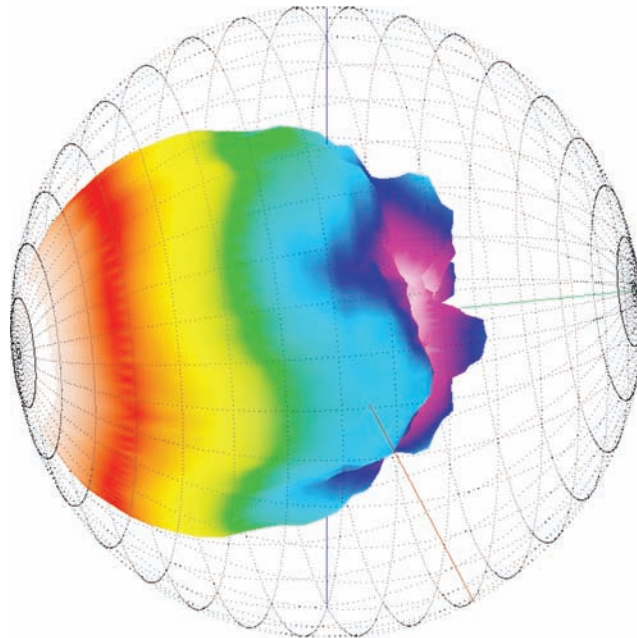

# SCIENTIFIC SOFTWARE FOR INTEGRATORS, ENGINEERS & ACOUSTICAL CONSULTANTS

---

Acoustical Design — Analysis — Presentation



# An Evolving Suite of Tools for Audio Professionals



- Design & Simulation – advanced mathematical models
- Smooth Workflow – document exchange
  - Presentations – color maps to virtual reality
  - Measurement Integration – design optimization & performance verification

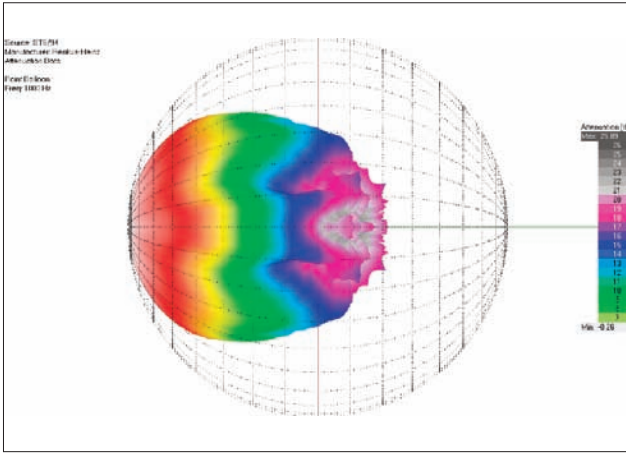

Since its introduction over 15 years ago, EASE has grown from a single MS-DOS program into a powerful and versatile suite of Windows® software. AFMG (Acoustic Design Ahnert & Software Design Ahnert) continues to expand and evolve the mathematical and acoustical algorithms, graphical user interfaces, and the tools for presenting and analyzing both measured and predicted acoustical data.

Today, the EASE software suite provides system designers and consultants with an invaluable set of tools for all aspects of professional practice, from detailed, realistic modeling and simulation of venue acoustics and sound system performance to informative and engaging client presentations, to comprehensive measurement and verification.

EASE & EASE JR take the guesswork out of system design, help eliminate costly mistakes and reduce installation time. They help designers learn and grow by graphically displaying accurate predictions of real-world acoustics. EASE models are an ideal way to explore options and to learn what works and what doesn't work – before the virtual venue becomes a job site and changes are time consuming and expensive. AURA's advanced calculation engine is like an "acoustician's microscope."

With the EASEView and the Movie and Vision modules, designers can quickly and easily create convincing visual presentations of acoustical concepts. EARS lets designers and clients listen to a design proposal before it is ever built.

EASERA is the industry's most complete, accurate and flexible measurement software. It is tightly integrated with EASE – for example, measurements of the built project can be imported into EASE models for verification and refinement of acoustical predictions and performance maps.

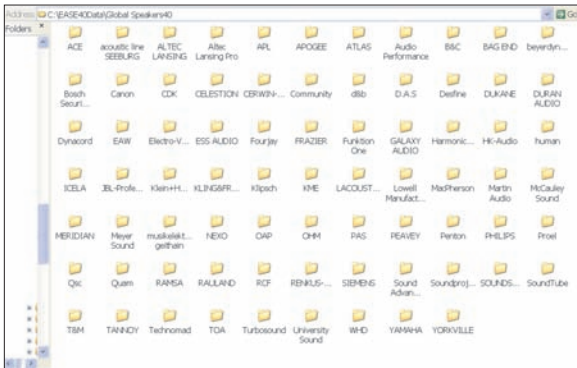

## Industry Standards

The ongoing evolution of EASE software means it continually becomes both more user-friendly and more accurate. Today, EASE and EASE JR are accepted and recognized worldwide as the standard-setters in acoustical modeling and simulation. Over 70 major loudspeaker manufacturers support the EASE database. Familiarity with EASE has become an essential qualification for audio professionals.

## An Investment of Lasting Value

### Lifetime Licensing: No Expiration Dates or Renewal Fees

EASE licenses are not time-limited, do not expire and never require a renewal or update fee.

### Free Updates & Program Enhancements

Over the past five years EASE licensees have received 9 major updates at no additional cost.

### Easy Upgrade Paths

At any time, licensees are free to upgrade the basic package from EASE Jr to EASE, purchase additional license keys or add expansion modules, with full credit for previous ownership.

### Outstanding Support & Training

Renkus-Heinz, the worldwide distributor for both EASERA and EASE software, has an expert technical support team that is only a phone call away. EASE training classes are held on a regular basis in Renkus-Heinz's Foothill Ranch facility. NSCA offers EASE training during NSCA Expo. SDA maintains active online user forums for EASERA software.

## Entry-Level Options

Access to all the benefits of an EASE software license – unlimited lifespan, continual updates with new features and enhanced realism and accuracy, ongoing educational and technical support – is surprisingly affordable. A 2-key EASE JR license is just \$800. EASE JR and EASERA can be purchased together for just \$1450. EASE is now available in a 2-key license as well: the base version of the software is only \$1300. Any EASE license can be upgraded as the professional needs and skills of the licensee require.





# EASE + EASERA = The Total Tool Set



## GLL - Generic Loudspeaker Library SpeakerLab

The Generic Loudspeaker Library (GLL) is a complex, descriptive and object-oriented data format, designed to store and exchange complex data on loudspeaker systems and acoustic sources of any kind, including:

- line arrays
- column loudspeakers and steered columns
- loudspeaker clusters and arrays
- multi-way loudspeakers.

Conventional loudspeaker and balloon directivity data typically reduce all loudspeaker systems to abstract single elements – a simplifying assumption that is no longer required in today’s era of cheap computer memory and processing power. Actual acoustical sources are more complex. Line arrays, for instance, often have variable rigging hardware and can assume multiple angular configurations. Column loudspeakers (both conventional and digitally controlled), clusters and vertical combinations of multi-way loudspeakers all differ radically from the “idealized” point source. Crossover and equalizer settings can alter the behavior of otherwise identical loudspeaker systems.

The Generic Loudspeaker Library was developed to take advantage of today’s faster computers and provide more detailed and accurate data for use in simulations. The object-oriented GLL dataset resolves most of the issues found in conventional loudspeaker databases. Each acoustic source (transducer) is treated as a separate acoustic source, while the loudspeaker enclosure is modeled as a loudspeaker enclosure. If crossovers, rigging hardware or external equalizers are part of a given system, they can be included in the dataset and configured in EASE or EASE JR.

EASE SpeakerLab is the software used to define GLL projects and compile them into GLL files for use in EASE. An EASE user loads the data and manipulates it to simulate the acoustic behavior of the device.

The GLL Viewer is a simple, freely distributed program that allows inspection of a GLL loudspeaker model.

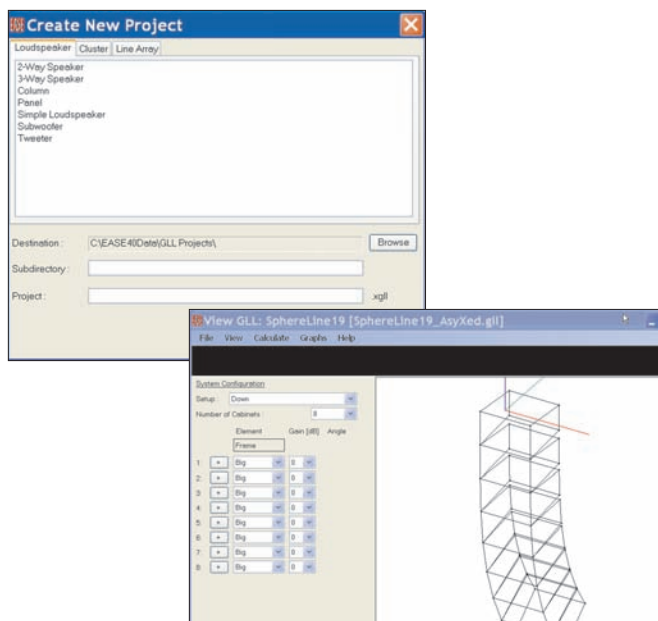

## Integrated Measurements for Design, Optimization & Performance Verification

### EASERA - EASERA PRO

EASERA puts dual-channel FFT (Fast Fourier Transform), RTA (Real Time Analyzer), MLS (Maximum Length Sequence) and TDS (Time Delay Spectrometry) measurement tools inside your laptop.

EASERA is an all-in-one measurement program. It includes a Real Time Analyzer, Signal Generator, Measurement Program and extensive Post processing features. EASERA is:

- Affordable and Expandable
- Simple to use
- Flexible and Fast
- Highly Accurate

EASERA data can be stored for post-processing and is easily imported into EASE models for design refinements and performance verification. The EARS auralization module can convolve Impulse Response (IR) measurements from EASERA with EASE models to produce full-confidence binaural auralizations.

The comprehensive EASERA test and measurement system is designed for working professionals. No more lugging around heavy boxes of equipment - EASERA puts everything you need inside your laptop.

EASERA is a 2-channel program with sampling rates from 8 kHz to 48 kHz. EASERA PRO offers 32-channels with sampling rates up to 192 kHz; also features MLS capabilities, the ability to do in-situ material absorption characteristic measurements and advanced editing and post processing capabilities.

### EASERA SysTune

EASERA SysTune is a new software tool purpose designed for real-time live-sound applications. It simultaneously measures both time-domain and frequency-domain information using live program material even while an audience is present. This allows audio professionals to obtain frequency response, reverberation time and speech intelligibility measurements in occupied venues using just a reference signal, a microphone and SysTune. Newly developed, patent pending noise suppression and signal gating algorithms allow EASERA SysTune to acquire a room impulse response in 5 to 10 seconds and process the data in real-time using live program material as the test stimulus.

EASERA SysTune also has the ability to process up to 8 input channels simultaneously and present spatially averaged spectrum and transfer function displays to the user.

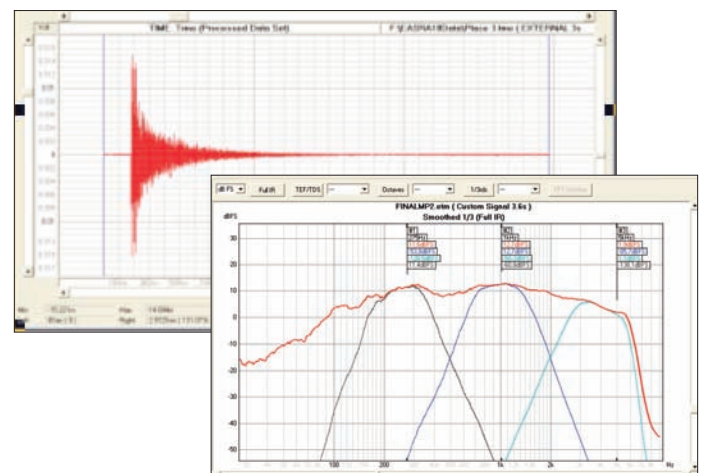



# EASE JR - Powerful Modeling & Presentation Software for Sound System Designers

A System Designers Best Friend

## An Industry Standard for Over a Decade

EASE JR is designed to answer the needs of system designers who don't need all the sophistication and power of EASE. Many professionals find that EASE JR has all the tools they need to develop both effective sound system designs and convincing client presentations.

## Powerful Design Tools

The EASE JR tool set includes:

- An exceptionally user-friendly Windows-based GUI
- Easy to use 3D modeling and room drawing functions, including user-customizable templates for commonly encountered room types.
- The industry's most complete open Loudspeaker Database, continually updated and expanded with data on thousands of loudspeaker models from over 70 major manufacturers.
- An open Surface Material Database that includes over 175 surface materials.

## A wide range of simulations, all based on scientifically verified calculations

- Direct SPL
- Alcons
- RASTI
- Total SPL
- Direct/Reflected Sound Ratios
- Critical Distance
- C Measures
- Arrival Times
- Loudspeaker Coverage Overlap
- Loudspeaker Aiming

## Essential Analytical Functions

### Ray Tracing

EASE JR's Ray Tracing function shows room reflection patterns – absolutely essential for troubleshooting any design.

### Direct Sound Auralization

With this function, you can actually listen to a multi-loudspeaker system before it is installed. Mis-alignments are immediately audible and easily corrected in the design stage.

## Professional Presentation Tools

Convincing the client is an essential step on the road to a successful project outcome. EASE JR gives you the tool set you'll need to show your work in formats that building owners, managers and other end users can understand and appreciate.

### Movie Module

The Movie Module provides an educational animated display of sound propagation. It's one more way EASE JR can provide detailed insight into the performance of your sound system design, before it is installed.

### Vision Module

EASE JR's Vision architectural rendering module takes you beyond 3D modeling. It gives you the power to apply light sources and textures to your surfaces, generating stunning photo-realistic images.

### OpenGL Viewer

EASEView is included with EASE JR. This OpenGL client program makes it easy to share EASE graphic files with your clients.

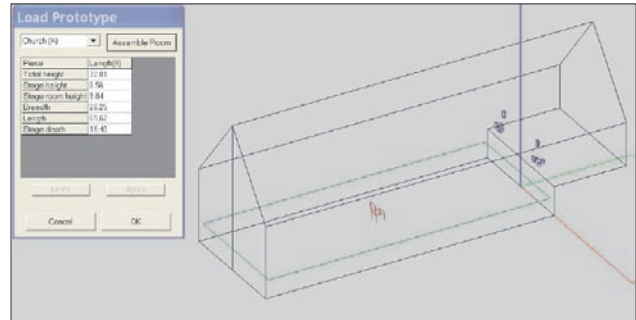

One of 33 prototype room models that speed room modeling

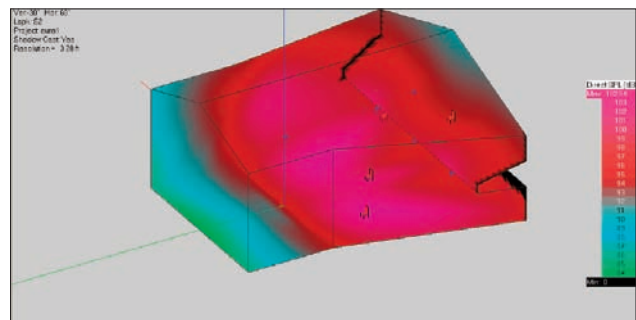

Direct SPL displayed on room surfaces

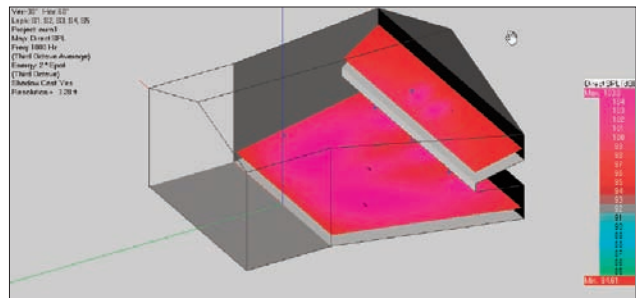

Direct SPL displayed on Audience Areas

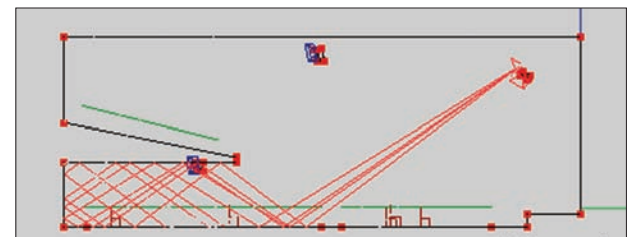

Ray Tracing display of floor reflections

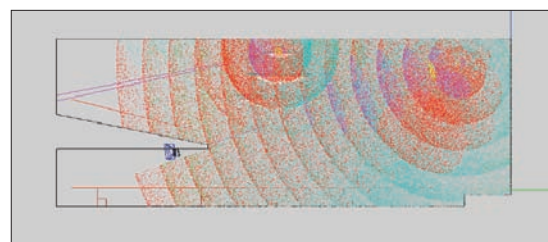

Movie shows propagation of sound into the room



# EASE - Comprehensive Modeling and Acoustic Analysis Software For World Class Venue & Sound System Design

Setting the Acoustical Standard for Over 15 Years

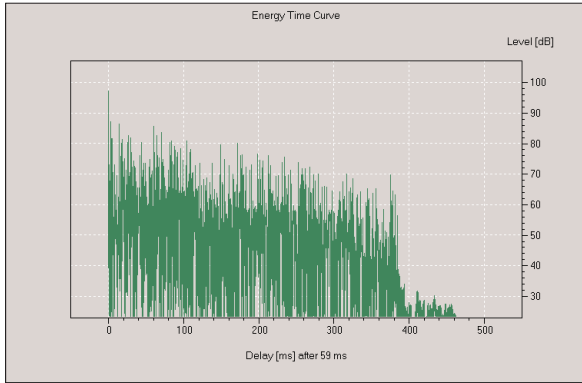

A typical EASE Reflectgram

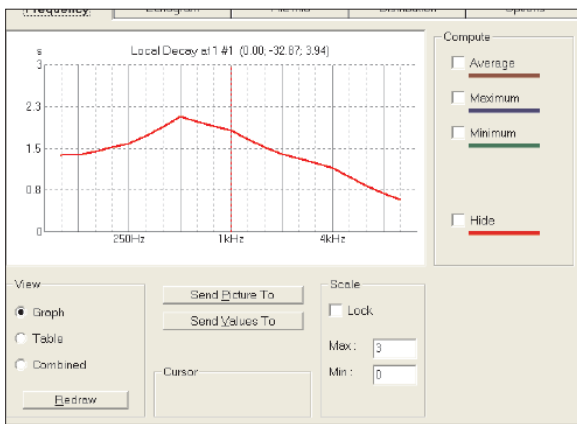

Local Decay Time graphic

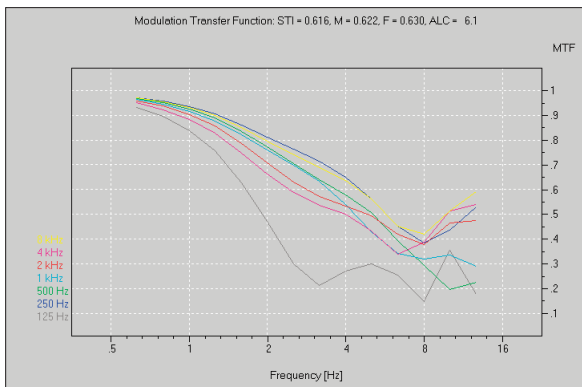

MTI and STI Window

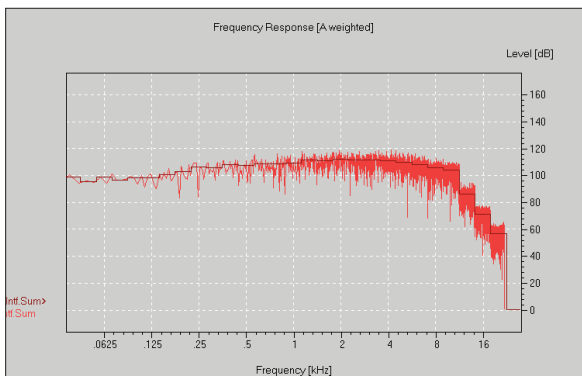

Typical frequency response plot

## Advanced Design Tools

EASE provides all of the simulation and presentation features offered by EASE JR, and adds extensive ray tracing and acoustical analysis capabilities. The advanced EASE tool set includes:

### Local Decay Times

Local Decay Times is a confidence-checking function that uses Ray Tracing to provide a quick check on the accuracy of the Eyring or Sabine RT calculations. Both EASE and EASE JR use Eyring or Sabine formulas to develop RT (reverberation decay time) values based on a model's volume and absorption characteristics and then uses these RT times to calculate other measures, such as Alcons, Rasti and D/R Ratios. The accuracy of these generalized mathematical assumptions varies from room to room. For example, the formulas are based on the room's absorption being distributed evenly on the room's surfaces, an assumption that doesn't hold true in many of today's rooms. The formulas also develop only a single set of RT values for the entire model: an actual room's RT varies from one location to another.

### Mapping with Reflections – Enhanced Accuracy

Mapping With Reflections uses Ray Tracing to develop local RT figures, which are then fed back into the mapping calculations to improve prediction accuracy.

### Local Ray Tracing

Local Ray Tracing saves time by using ray tracing "snap shots" to quickly identify problem areas that need more detailed investigation using Impact Studies.

### Impact Studies & Acoustical Probe

EASE offers two different methods of Impact Studies. Both use ray tracing to register and store data on all rays impacting a specific location within the model over the length of the investigation. Data stored for each ray, at each frequency, includes arrival time, energy (SPL) level and direction (arrival angle).

The Acoustical Probe is then used to calculate, map and display the detailed acoustical data required for discovering optimal solutions in problem areas.

Available displays include:

- Reflectograms (EFC/ETC displays)
- Schroeder RT Times
- Modular Transfer Function (MTF)
- STI Intelligibility Projections
- Impulse Response Files.

### Modular & Extensible

EASE is modular in design, fully extensible with powerful calculation and simulation packages for specialized design tasks. The AURA module extends the mathematical rigor and sophistication of the program's acoustical modeling. The advanced real-time auralization functions of the EARS module facilitate the creation of immersive virtual-reality presentations.



# AURA - Analysis Utility For Room Acoustics

## Rigorous Mathematical Modeling For Acousticians - Greater Precision, Faster Calculations

### Advanced Acoustical Modeling Algorithms

AURA's highly efficient "Caesar" algorithms drastically reduce the calculation time for reflection studies, without compromising accuracy.

AURA calculates with greater detail, employing both diffusion/scattering and ray tracing models. This enhances the accuracy of all calculations, ensuring the most accurate predictions, even when dealing with complex room models and the increasingly complex systems, such as line arrays, that are installed in those rooms. AURA generates more detailed impulse responses that can be used by EARS to generate even more realistic and accurate auralizations.

AURA includes Echograms for both music and speech. Echograms predict the effects of seriously delayed energy spikes on speech intelligibility or musical coherence. AURA identifies potential problems in the design stage, where they can be corrected most easily and inexpensively.

### An Acoustician's Acoustical Microscope

AURA calculates all the key room acoustical parameters defined in ISO 3382, the International Standard on Room Acoustical Measurements. ISO 3382 measures take into account the subjective aspects of the listening experience. They provide a more accurate and complete indication of listeners' perceptions of both speech and music than traditional parameters such as RT60 and Critical Distance.

AURA Calculates:

- Early Decay Times
- T10, T20 & T30 Reverberation Times
- Lateral Fraction (LF)
- Lateral Fraction Coefficient (LFC)
- Clarity (C80)
- Definition (C50)
- Sound Strength
- Center Time
- Plus Direct SPL, Total SPL, STI and Articulation Loss

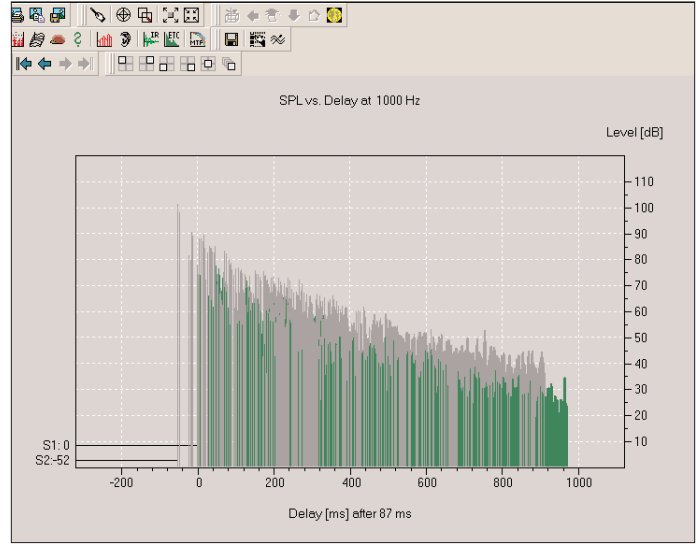

A typical AURA Reflectogram

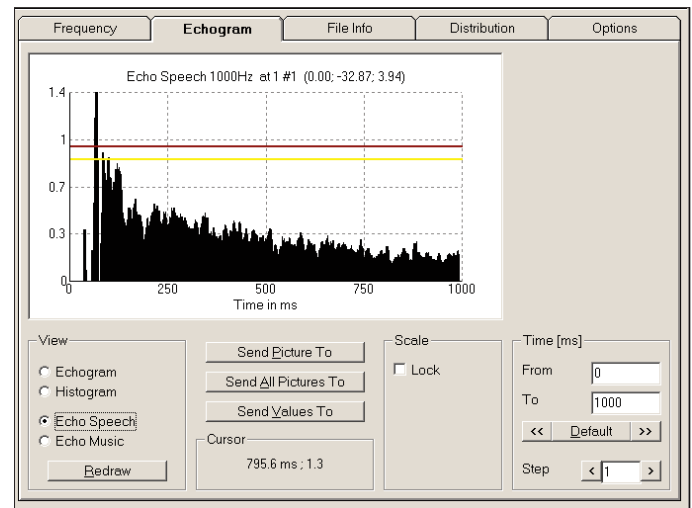

EchoSpeech Echogram

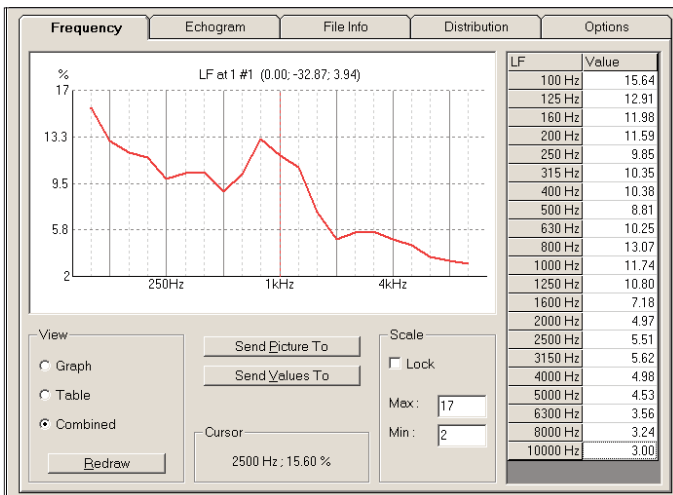

LF (Lateral Fraction) Display

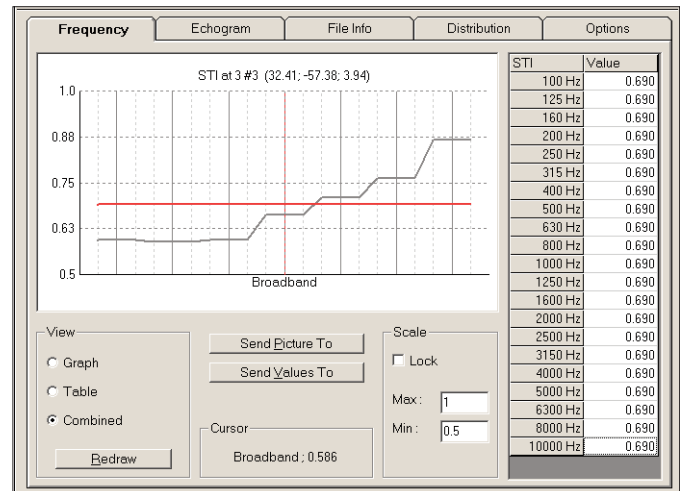

MTI and STI Display



# EARS - Electronically Auralized Room Simulation

Let your EARS be the judge of a room and sound system, before the room is even built.

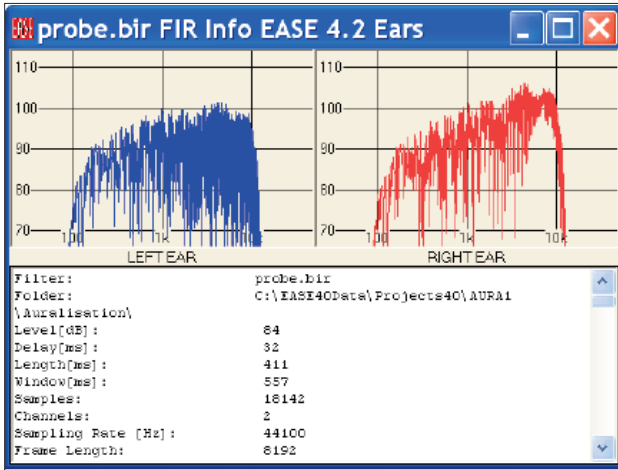

## Believe Your EARS

The listening experience is the ultimate criterion for a project's success or failure. The EARS module lets you conduct subjective listening tests during the design phase, when problems are easily corrected. Auralizations can be replayed for close, critical listening to discover undesirable colorations, flutter echoes, slap-back reflections and other problems.

EARS provides remarkably realistic binaural auralizations that take into account the latest psychoacoustic research. There's no better way to prove the value of a new sound system or the need for additional acoustical treatment than to let the client hear how it will sound.

The auralization process begins with an impulse response: the acoustical signature of a specific location within the venue. This can be calculated by EASE or AURA or measured by EASERA or EASERA Pro. The audio program (typi-

cally speech, music or both) is convolved with the impulse response. A "head transform" is then applied to the auralization to produce separate signals for the left and right ear. This binaural output enables the listener to experience the room and the sound system with full dimensionality and realism.

## IR: Mapping the Infrared Spectrum

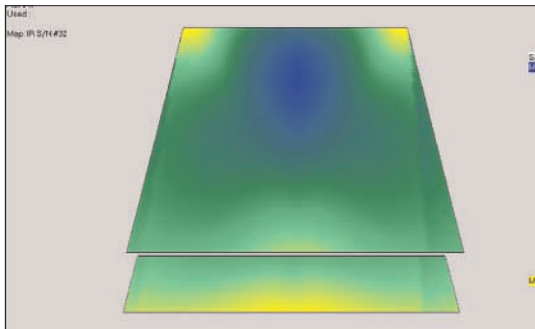

IR Signal/Noise Display

Infrared (IR) systems are the most common Assisted Listening systems installed to fulfill requirements of the Americans With Disabilities Act and other government regulations.

With the IR module, the performance of infrared systems can be simulated, analyzed and accurately predicted. Transmitters and Modulators are the infrared sources, and signal-to-noise mapping is used to predict system performance.

## Hardware / Software Requirements

**EASE** and **EASE JR** run under Windows 98, Windows 2000, Windows XP, Windows NT and Windows Vista operating systems on any computer with VGA graphics capability.

Windows 95 is not supported: Windows ME (Millennium) is not recommended.

**EASE** requires a minimum of 600 MB of hard disk space

Minimum requirements are easily met by today's PCs and laptops: 128 MB or more of RAM, 300 MHz or higher clock speed and at least 2 Gigabytes of hard disk space. 500 MHz or higher clock speeds and a minimum of 256 MB RAM are recommended for advanced EASE users and for users of AURA and EARS. EARS requires a full duplex stereo sound card to output complete binaural auralizations.

## VISION: Photo-Realistic Renderings

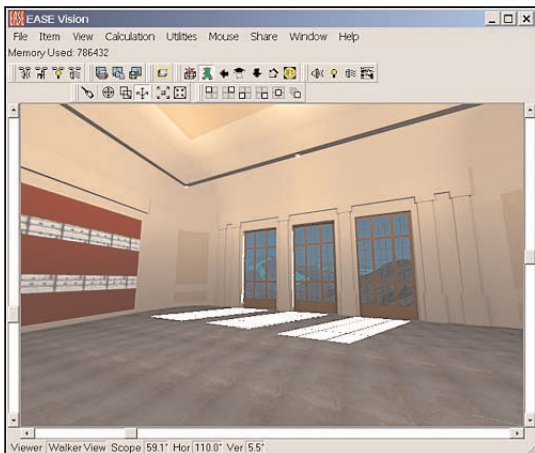

VISION graphic; note the scenery

The 3D rendering power of VISION is part of EASE and EASE JR. It produces photo-realistic images of any model by adding lights of different directional characteristics, colors and intensities to produce shading, shadows and other realistic effects. Surface textures can be either reflective, shiny, dull, rough, or transparent. Applying bitmaps (photos of materials, scenes, etc.) to the surfaces creates realistic stone or brick walls, tile floors, even pictures, decorative objects or other details.

## Ahnert/Feistel Media Group:

### ADA (Acoustic Design Ahnert) & SDA (Software Design Ahnert)



Ahnert Feistel Media Group (AFMG) originated in the late 1980's. Through his work with AKG on the Delta Stereophonic System, Prof. Dr.-Ing. habil. Wolfgang Ahnert realized the importance of accurate acoustical design and analysis software. After scientific studies at Lomonossov University in Moscow, he teamed up with Dr. rer. nat. habil. Rainer Feistel, Professor of Theoretical Physics at Rostock University, to develop a computer program capable of scientifically simulating the Delta Stereophony concept. Dr. Ahnert applied his thorough theoretical training and practical experience in acoustics to design the software concepts. Dr. Feistel contributed both advanced calculation algorithms and user interface programming.

Soon after the Berlin Wall fell in 1989, ADA Acoustic Design Ahnert was founded. The previously-developed software prototype was given a functional interface and a now-familiar name: EASE (Electro-Acoustic Simulator for Engineers). EASE was first introduced to the professional audio industry in 1990 at

the 88th AES Convention in Montreux. Shortly thereafter, Renkus-Heinz became the worldwide distributor of the English-language version.

The rapid acceptance of EASE by professional acousticians and sound system designers encouraged the development team to expand the program's functionality and refine its accuracy, leading in 1994 to the last release for MS-DOS – EASE 2.1. Dipl.-Phys. Stefan Feistel joined the development team in 1995 to port EASE to the Windows operating system. EASE 3.0 was released in 1999 as the first version of EASE to run in the more user-friendly Windows environment. The growing availability of both desktop and laptop computing power, along with increased demand for modular extensions to the EASE software suite, led to the decision to form a new company in order to put the software development on a professional basis. SDA Software Design Ahnert GmbH was founded in 1999. Its first goal was the development of a new software-based measurement platform that would unify all existing approaches in a modern format. The result, EASERA, was released in late 2004. Shortly after that the manufacturer-independent line array aiming and modeling program EASE Focus was released, along with other software packages engineered for professionals in the audio industry.

Today's Ahnert Feistel Media Group is composed of both ADA, which has expanded with satellite offices in Cairo, Egypt and Doha, Qatar, and SDA as well as the non-profit ADA - Foundation gGmbH. The mission of the ADA - Foundation is to support research into the science of acoustics by collaborating with leading universities in countries around the world, and by making academic discounts on AFMG-developed software available to students and researchers.

EASE and its related programs are an ongoing joint development project of ADA and SDA. EASE has become the de facto industry standard for acoustic design and analysis. This is due to a number of factors: open databases, a foundation in rigorous academic research, and continual improvements in functionality and user interface that take advantage of exponential growth in computer processing power and speed.

## Renkus-Heinz, Inc.



Renkus-Heinz has been researching the science and technology of sound since April 1, 1979. We are proud partners with Ahnert / Feistel Media Group as the worldwide distributors of EASE, EASERA and related software, and as a principal center for training and technical support.

Our involvement with AFMG is part of a relentless focus on accurate and natural reproduction of sound, speech and music that has produced 6 major US patents. Our pursuit of significant, measurable and audible improvements includes classic acoustical physics and advanced digital technologies as well as scientific software.

RHAON (the Renkus-Heinz Audio Operations Network), Iconyx Digital Controlled Array Systems and Reference Point Arrays exemplify our total systems approach. By exploding boundaries that separate loudspeakers, audio networking, signal processing, power amplification, cabling and hardware, we empower audio professionals to achieve excellence even in difficult conditions.

Our close working relationships with AFMG and other leading audio professionals worldwide expand our research and development capabilities. With advanced tools and innovative partners, we've solved problems for the most demanding houses of worship, sports centers, transportation terminals, performing arts centers, themed entertainment producers, cruise ships, event production teams, etc. Working together, there's no problem we can't solve.

EASE - Distributed Worldwide by:

